



NJ-21G58

Server Slides (Columbus)
75 pound class (35 kgs)

» Information » Structure » Specification Table » Installation Instructions

Information



Range Side View Drawer

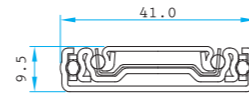

Side Clearance | 7.5 mm (functional space) maximum chassis width 438 mm.

Height | 41.0 mm

Loading | 75 pound (35 kgs) class for 1000 cycles in 26" long

Feature | SB Tool-less, lock out

Finish | RoHS compliant zinc plating

Surface Treatment

- Clear Zinc
- Black Zinc
- Black E. Coating
- White E. Coating
- Stainless Steel

Packaging

- Retail

Product Photo



Structure

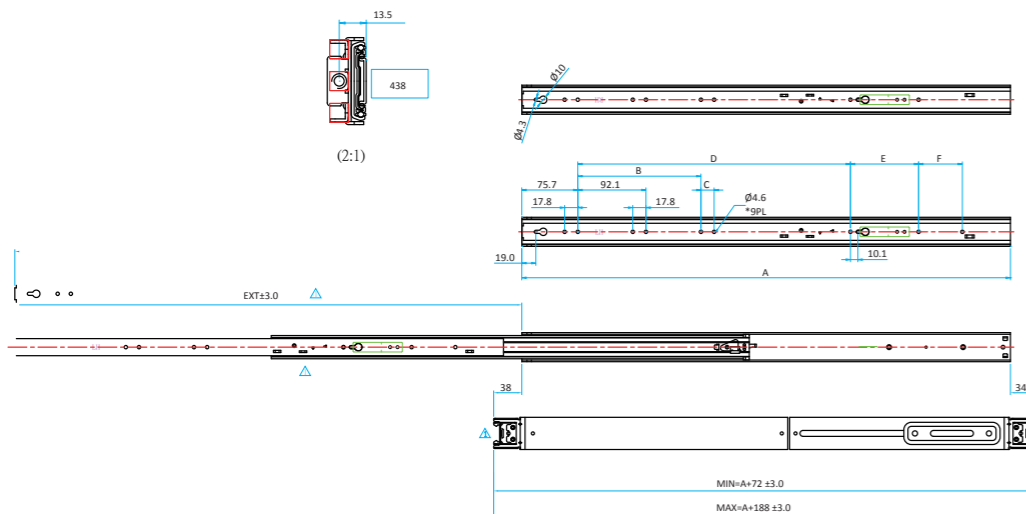

Section

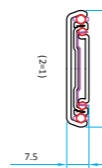

Component Parts

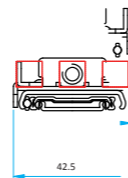

Specification Table

SIZE	A	B	C	D	E	F	EXT
20" (500mm)	508.0			276.3	92.1		532.7
22" (550mm)	558.0	166.4	17.8	317.2		55.0	589.2
24" (600mm)	609.6	166.4	17.8	368.4	92.1		634.3
26" (650mm)	660.4	166.4	17.8	368.4	92.1	55.0	685.1
28" (700mm)	711.0	166.4	17.8	460.5	92.1		735.9
30" (750mm)	762.0	166.4	17.8	460.5	92.1	55.0	786.7

Installation Instructions

QUICK INSTALLATION GUIDE OF NJ-21G58

Samurai Tool-Less Server Slide, 75 pound (35kgs) loading

4 STEPS TO THE SUCCESSFUL INSTALLATION!!

A. Please go through this guide thoroughly before installation. Please note that the 100lb- grade SB Tool-less is designed and built for 1U and 2U chassis. Not recommended for 3U or above applications.

B. The SB bracket is for EIA rail with 5/8" pitch and square holes, and can only be mounted behind the rail. You will need to purchase transfer bracket in order to mount SB bracket on the rail with round holes. The standard retail packaging shall include one piece of left hand, one piece of right hand 4 pieces of H-370 screws for ear plate fastening and 2 pieces of H-207 screws for chassis fastening.

* Standard screw kit does not apply to chassis which is designed to be screw mounted.

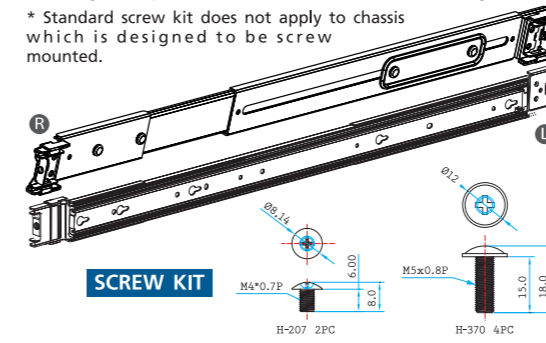

After installation or maintenance is finished, you may secure the server by putting screw through the center hole on bracket.

SB tool-less bracket is built for EIA bracket with square holes at 5/8" pitch. It doesn't work with 1/2" pitch.

Step 1 > Remove the chassis (inner) member

↓ Pull the slide open. Then press the trigger down as shown on the drawing, and pull the chassis (inner) member out. (Figure1-1)

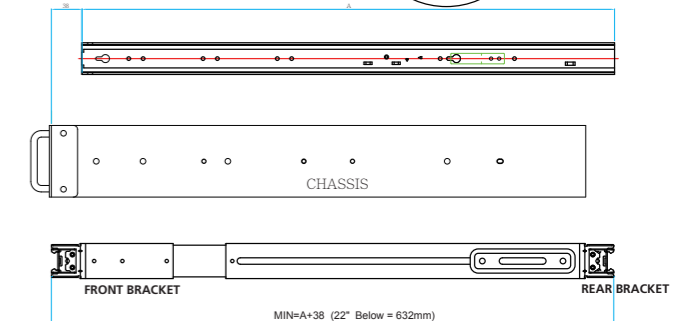
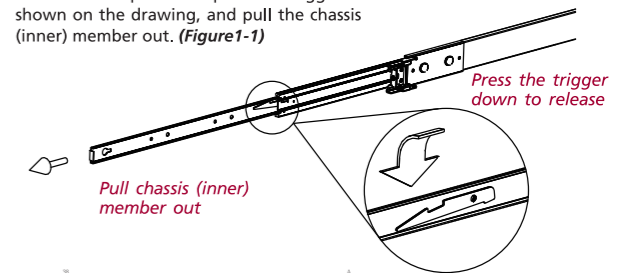

**Extendable front bracket only apply to some Tool-less model EXT=300MM

Step 2 > Mount the chassis (inner) member to the chassis

↓ You may opt for M4 or M5 pan head screw. The screw head of either M4 or M5 can not exceed 2.0 mm. Alternatively, you may mount the

slide member to the chassis through standoffs. Likewise, the head of stand-off can not exceed 2.0 mm. Each side of chassis is highly suggested to use 3 of screws or standoffs for slide attachment.

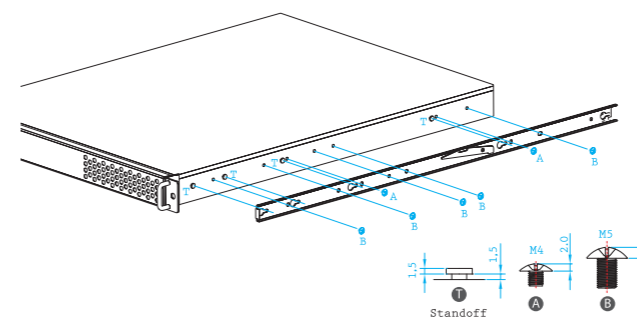

Uninstall the bracket

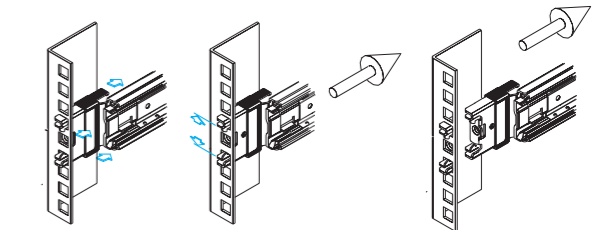

Step 3 > Mount the chassis into the cabinet

↓ Insert the chassis (inner) member into the cabinet member as shown on the drawing. It is important to check if the ball retainer is in fully open position before install the chassis.

It might cause catastrophic damage to the chassis if ball retainer is not in fully open position while mounting the chassis. While you are pushing chassis back to the cabinet, you need to release the slide from locking position by pressing the trigger down.

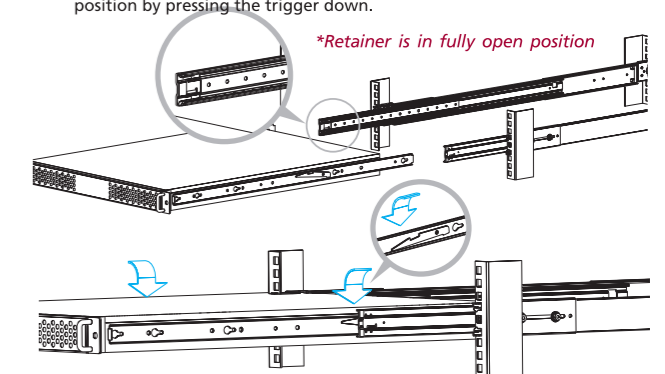

Step 3 > Attach the cabinet (outer) member to the rail

↓ Insert the stag into the upper and lower square holes on EIA rail from the back of rail.

Push the safety lock forward to secure the bracket. It is important to check if the safety lock is in unlocked position before mounting the brackets .

